

COMPAC[®]

PRODUCENT SIDEN 1946



KATALOG NR. 11A





Sådan skaber Compac værdi

4-7



Donkraft med lav indsatsenhøjde 2 ton



8



Donkraft med lavt chassis 2 ton



9



Donkraft til varebiler, 4WD og minibusser 3 ton



10



Donkrafte 4 - 15 ton



11



Højtløftende donkrafte 1,4 - 2 ton

NYHED



12



Højtløftende donkrafte 3 - 10 ton



13



Lufthydrauliske donkrafte

NYHED



14-15



Lufthydrauliske donkrafte

NYHED



16



Hydrauliske oprettersæt



17



Hjulløfter til biler, varebiler og 4WD



18



Hjulløftere til lastbiler og busser



19



Hjulløfter til landbrugs- og entreprenørmaskiner



20-21



Værkstedskraner



22-23



Universale gearkasseløfter

Tilbehør til gearkasseløftere



24-25



**Teleskopisk gearkasseløfter
til biler, varebiler og 4WD**



26



**Teleskopisk gearkasseløfter
til lastbiler og busser**



27



Fjederspændepresse



28-29



**Fodbetjente
værkstedspreser 16 - 25 ton**



30



**Håndbetjente
værkstedspreser 20 - 25 ton**



31



**Fodbetjente
værkstedspreser 40 - 50 ton**



32



**Håndbetjente
værkstedspreser 40 - 100 ton**



33



**Elektro-hydrauliske
preser 40 - 100 tons**



34-35



Støttebukke 2 - 12 ton

Flaskedonkrafte 3 - 50 ton



36

SÅDAN SKABER COMPAC VÆRDI **Lifting is serious business – We know!**

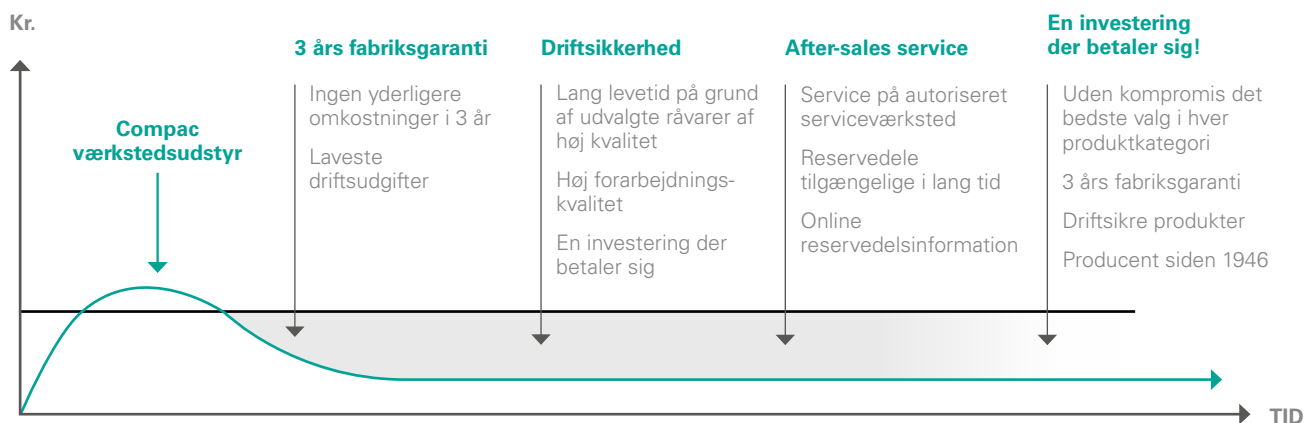

FABRIKS- GARANTI

Compac satte et benchmark helt tilbage i 2007 ved at være den første producent som tilbyder 3 års garanti.





HISTORIE

Fire målrettede danskere etablerede Compac i 1946. Deres vision var at fremstille fremragende donkrafte. Denne vision er uændret gennem de seneste mere end 70 år og vi er stolte over at kunne fortsætte vores daglige bestræbelser på at styrke det stærke omdømme for fremragende kvalitet som er opbygget gennem mange år.

KNOW-HOW ER FORSKELLEN



PRODUCENT SIDEN 1946

Compac har produceret hydrauliske produkter i høj kvalitet siden 1946. Målet for vores produktion er at fremstille produkter af høj kvalitet med den primære målsætning at skabe tilfredse kunder.



RESERVEDELE TILGÆNGELIGE I LANG TID

Reserve- og sliddele til Compac produkter er lette at identificere og få fat i. Information om reservedele til alle Compac produkter er let tilgængelig på www.compac.dk og på Compac's App.



ONLINE INFORMATION

Let tilgang til alt reservedelsinformation. Find den rette løsning til jobbet. YouTube film giver en bedre forståelse af bruger fordelene. Reparationsvejledninger med trin-for-trin vejledning, så man oftest kan fejlsøge og reparere produktet på stedet. Betjeningsvejledninger.



RÅVARER I HØJ KVALITET

Compac's hydrauliske komponenter er producerede in-house ved brug af råvarer i høj kvalitet. Vigtige råvarer som hydrauliske cylinderrør, pakninger, ventilblokke, m.m. sources alene fra højkvalitetsleverandører. Der er ingen kompromiser vedrørende kvaliteten af de kritiske råvarer som bruges i fremstillingen af Compac's hydraulik systemer.

UNIKT KVALITETSSYSTEM

Compac opererer med et unikt kvalitetssystem der er inspireret af den Japanske tilgang til kvalitet. Det omfattende kvalitetssystem kombinerer kvalitets-holdningen hos hver enkelt medarbejder med den personlige kvalitetsansvarlighed hos alle der er involverede i produktionsprocessen.



PRODUCENT SIDEN 1946



DONKRAFT MED LAV INDSATSHØJDE 2 TON BILER



Ideel til løftepunkter langs panel kanter.



Ergonomisk kørestang.

"Løft-og-drej" sænkesystem sikrer imod utilsigtet nedsækning.

Fuldt svejst konstruktion.

Maks. højde 500 mm.

Fodpedal til hurtigt løft til løftepunktet.

Cylinder beskyttet mod skidt, svejseslagger, m.m.

Min. højde 80 mm.

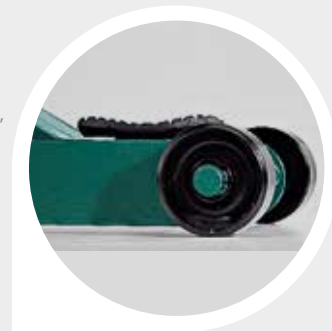

Lavt indstik.

Sikkerhedsventil sikrer kontrolleret nedsænkningshastighed selv under maksimal belastning.

Hydraulisk sikring mod overbelastning.

Støjreducerende nylonhjul.

TILBEHØR



1002LF
Gummisaddel beskytter løftepunktet.



3068
Saddel til løft på løftepunkter placeret oppe bag skorter. (+ 40 mm)



60245
Hårdgummihjul. (Fabriksmonteret)



Bogie PU
Bogie system med polyurthan ruller. (Fabriksmonteret)

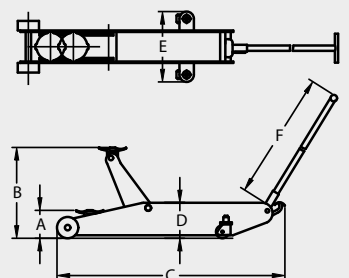

Model	Max (ton)	A (mm)	B (mm)	C (mm)	D (mm)	E (mm)	F (mm)	Kg
2T-C	2	80	500	730	160	380	925	37



DONKRAFT MED LAVT CHASSIS 2 TON BILER



YouTube

Søgeord:
Compac 2T-77



Ekstremt lavt chassis forbedrer adgang under lave køretøjer.



Lavt chassis med lang rækkevidde forbedrer adgang til løftepunkter dybt under køretøjer.

Fodpedal til hurtigt løft til løftepunktet.

Ekstremt lavt chassis, så donkraften kan komme under "alle" biler.

Lavt indstik kun 77 mm.



Lavt indstik.

TILBEHØR



1077
Gummisaddel beskytter løftepunktet.



3068
Saddel til løft på løftepunkter placeret oppe bag skorter. (+ 40 mm)



60245
Hårdt gummi hjul. (Fabriksmonteret)



Bogie PU
Bogie system med polyurthan ruller. (Fabriksmonteret)

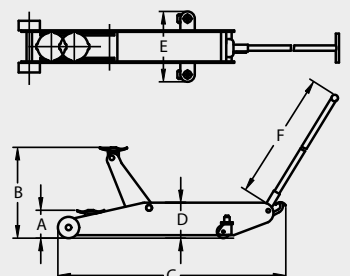

Model	Max (ton)	A (mm)	B (mm)	C (mm)	D (mm)	E (mm)	F (mm)	Kg
2T-77	2	77	480	950	126	380	925	41



DONKRAFT 3 TON

VAREBILER, 4WD OG MINIBUSSER



Chassis med lang rækkevidde forbedrer adgang til løftepunkter dybt under køretøjer.



TILBEHØR



1002LF
Gummisaddel beskytter løftepunktet.



3068
Saddel til løft på løftepunkter placeret oppe bag skørter. (+ 40 mm)

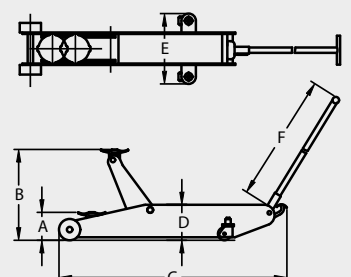

Model	Max (ton)	A (mm)	B (mm)	C (mm)	D (mm)	E (mm)	F (mm)	Kg
3T-C	3	115	500	1015	170	380	925	42



DONKRAFTE 4 - 15 TON LASTBILER OG BUSSE



Lavt chassis med lang rækkevidde forbedrer adgang til løftepunkter dybt under lastbiler. **10T-C med tilbehør 60200**



**You
Tube**

Søgeord:
Compac 10TC

Ergonomisk kørestang.



Fodpedal til hurtigt løft til løftepunktet.



TILBEHØR



60200
Luftgummihjul kan monteres på balancepunkt, så donkraften bliver markant lettere at manøvrere. Bliver midlertidigt flade under belastning.

Model	Max (ton)	A (mm)	B (mm)	C (mm)	D (mm)	E (mm)	F (mm)	Kg
4T-C	4	130	545	1270	200	465	1045	70
5T-C	5	145	560	1270	200	465	1045	71
6T-C	6	155	570	1395	210	470	1045	90
10T-C	10	165	580	1410	225	435	1045	106
12T-C	12	170	670	1700	280	470	1045	150
15T-C	15	200	600	1790	325	475	1045	162

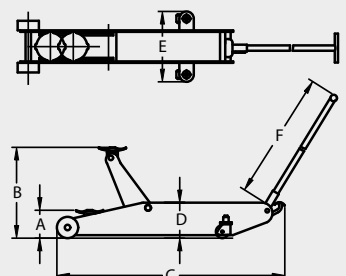



HØJTLØFTENDE DONKRAFTE 1,4 - 2 TON BILER



Maks. højde 715 mm.

1,4T-HC 77

Fodpedal til hurtigt løft til løftepunktet.

Lavt indstik kun 77 mm.

TILBEHØR



Model	Nr.
-------	-----

1,4T-HC 77	1077
------------	------

2T-HC	1002LF
-------	--------

Gummisaddel beskytter løftepunktet.



Bogie PU

Bogie system med polyurthan ruller. (Fabriksmonteret)



NYHED

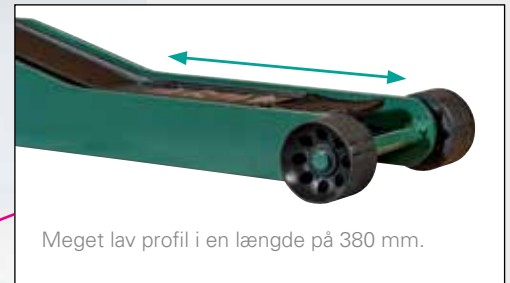

Meget lav profil i en længde på 380 mm.

Sikkerhedsventil sikrer kontrolleret nedsænkningens hastighed selv under maksimal belastning.

Lav profil forbedrer adgang til løftepunkter dybt under de fleste køretøjer.

Model	Max (ton)	A (mm)	B (mm)	C (mm)	D (mm)	E (mm)	F (mm)	Kg
1,4T-HC 77	1,4	77	715	1050	190	380	925	43
2T-HC	2	98	735	1035	200	380	1045	53

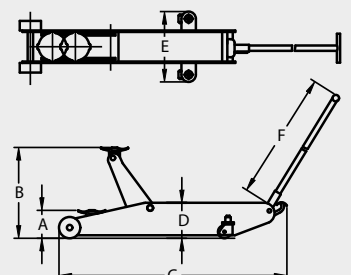



HØJTLØFTENDE DONKRAFTE 3 - 10 TON

VAREBILER OG LANDBRUGSMASKINER



TILBEHØR



60200
Luftgummihjul kan monteres på balancepunkt, så donkraften bliver markant lettere at manøvrere. Bliver midlertidigt flade under belastning.

Maks. højde 860 mm.

8T-HC med tilbehør 60200

Ergonomisk kørestang.



3T-HC

Maks. højde 960 mm.

"Løft-og-drej" sænkesystem sikrer imod utilsigtet nedsænkning.

Sikkerhedsventil sikrer kontrolleret nedsænkningshastighed selv under maksimal belastning.

Fuldt svejst konstruktion.

Hydraulisk sikring mod overbelastning.

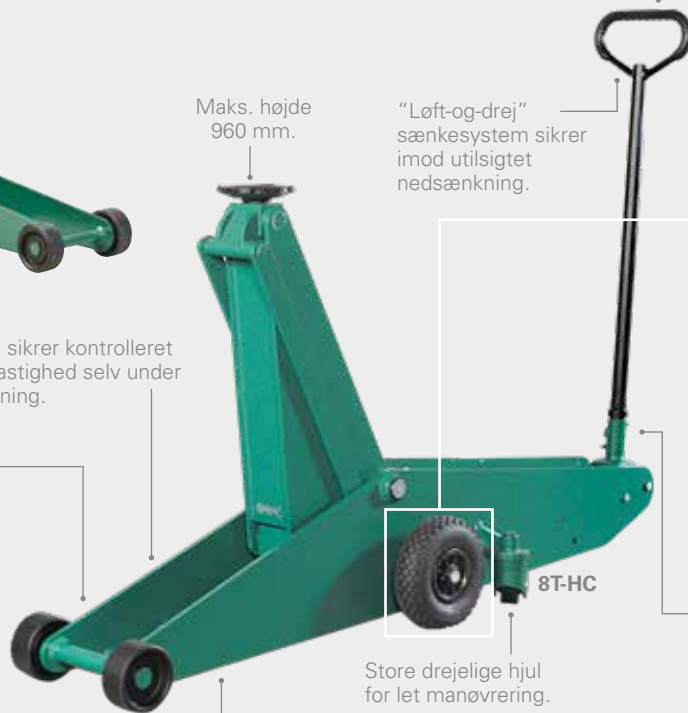

8T-HC

Store drejelige hjul for let manøvrering.



Fodpedal til hurtigt løft til løftepunktet.

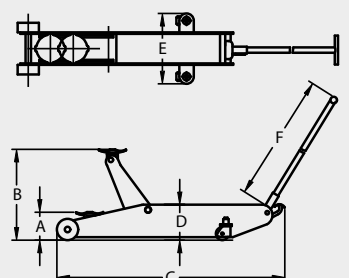

Model	Max (ton)	A (mm)	B (mm)	C (mm)	D (mm)	E (mm)	F (mm)	Kg
3T-HC	3	130	860	1620	210	460	1045	88
5T-HC	5	180	960	1830	350	475	1045	181
8T-HC	8	180	960	1830	350	475	1045	186
10T-HC	10	210	710	1700	290	475	1045	139



LUFTHYDRAULISKE DONKRAFTE LASTBILER OG BUSSE



A5816-C

LAVE TELESKOPDONKRAFTE



STANDARD



TILBEHØR



0Y1600
Forlængersæt.
3 x 20 mm. 1 x 10 mm.



0Y2618
"V" sadel til løft
på aksler og runde
løftepunkter.



0Y1407
Sadel Ø140.



Søgeord:
Compac A4020-C



Søgeord:
Compac A5816-C

Model	Max (ton)	A (mm)	B1 (mm)	B2 (mm)	B3 (mm)	B4 (mm)	C (mm)	D (mm)	E (mm)	F (mm)	Kg
A3216-C	32/16	150	220	300	-	500	495	168	310	1230	43
A4020-C	40/20	150	220	300	-	500	495	168	310	1230	44
A5816-C	58/32/16	120	165	210	255	455	665	130	305	1360	52

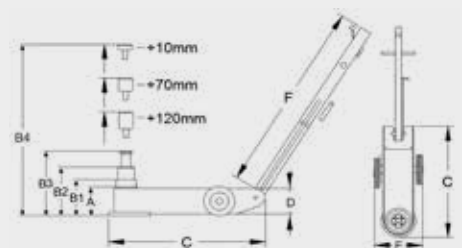



LUFTHYDRAULISKE DONKRAFTE

LASTBILER OG LANDBRUGSMASKINER



A28-HC

EKSTRA HØJ LUFTHYDRAULISK DONKRAFT OG TELESKOPDONKRAFT MED EKSTRA HØJ LØFTEKAPACITET

Stor maksimumshøjde
på 780 mm med brug
af forlængere.

Kraftig, ét trins
cylinder med
lang slaglængde.

Lang kørestang for
bedre rækkevidde.

Kort chassis for
let manøvrering.

NYHED



A28-HC

A4422-C

Model	Max (ton)	A (mm)	B1 (mm)	B2 (mm)	B3 (mm)	B4 (mm)	C (mm)	D (mm)	E (mm)	F (mm)	Kg
A28-HC	28	350	580	-	-	780	735	160	280	1230	58
A4422-C	44/22	217	341	467	-	667	525	168	300	1230	46
A5830-C	58/30	220	330	450	-	650	1050	150	350	1360	80

STANDARD



10 mm. 70 mm. 120 mm.

Samlet 200 mm forlængelse.

TILBEHØR



0Y1600
Forlængersæt.
3 x 20 mm. 1 x 10 mm.



0Y2618
"V" sadel til løft
på aksler og runde
løftepunkter.



0Y1407
Sadel Ø140.

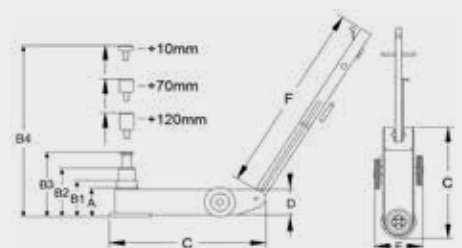



LAV LUFTHYDRAULISK DONKRAFT 1,6 TON BILER



Lavt chassis med lang rækkevidde forbedrer adgang til løftepunkter dybt under køretøjer.

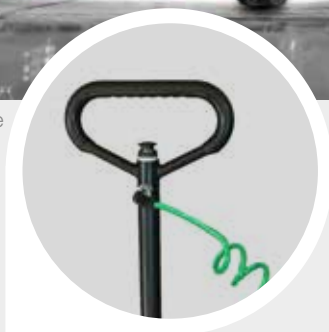

Hurtig og lydløs luftpumpe. Mindre end 70 dB.



Maks. højde 480 mm.

NYHED
LUFTHYDRAULISK

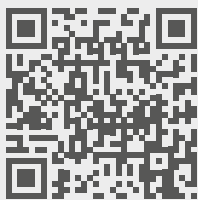

Søgeord:
Compac A1,6T-77



Ekstremt lavt chassis forbedrer adgang under lave køretøjer.



Ekstremt lavt chassis, så donkraften kan komme under "alle" biler.

Lavt indstik kun 77 mm.



Lavt indstik.

TILBEHØR



1077
Gummisaddel beskytter løftepunktet.



3068
Saddel til løft på løftepunkter placeret oppe bag skorter. (+ 40 mm)



60245
Hårdt gummi hjul. (Fabriksmonteret)



Bogie PU
Bogie system med polyurthan ruller. (Fabriksmonteret)

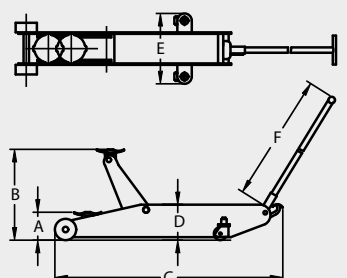

Model	Max (ton)	A (mm)	B (mm)	C (mm)	D (mm)	E (mm)	F (mm)	Kg
A1,6T-77	1,6	77	480	950	126	380	925	51



HYDRAULISKE OPRETTERSÆT

BILER, LASTBILER OG LANDBRUGSMASKINER



CRK 4	CRK 10
1 Quick-lock adapterstykke, 400 mm.	Quick-lock adapterstykke, 475 mm.
2 Quick-lock adapterstykke, 300 mm.	Quick-lock adapterstykke, 350 mm.
3 Quick-lock adapterstykke, 200 mm.	Quick-lock adapterstykke, 250 mm.
4 Quick-lock adapterstykke, 100 mm.	Quick-lock adapterstykke, 125 mm.
5 "V" adapter.	"V" adapter.
6 Vinkeladapter med gevind.	Vinkeladapter med gevind.
7 Vinkeladapter.	Vinkeladapter.
8 Kileformet adapter.	Kileformet adapter.
9 Fod.	Fod.
10 Sadel.	Sadel.
11 Fleksibel gummiadapter.	Fleksibel gummiadapter.
12 Forbindelsesadapter.	Forbindelsesadapter.
13 Adskillelsesadapter. (Maks. 500 kg.)	Adskillelsesadapter. (Maks. 500 kg.)
14 Cylinder.	Cylinder.
15 Fleksibel tryksslange, 1800 mm.	Fleksibel tryksslange, 1800 mm.
16 4 ton hydraulisk pumpe.	10 ton hydraulisk pumpe.
17 Plastkasse.	Plastkasse med hjul.



ADVARSEL: Pumpens hydrauliske kapacitet overstiger maksimal kapaciteten på adskillelsesadapteren og andre adapterer. Se maksimale kapaciteter ved sammensætning af flere komponenter i instruktionsmanualen.



HJULLØFTER

BILER, VAREBILER OG 4WD

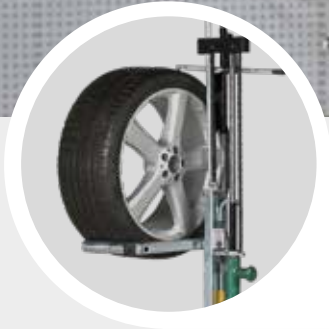

Hjulets decentrerede placering giver let adgang til hjulbolte.

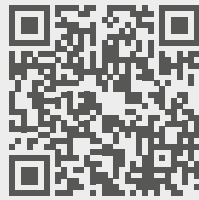

YouTube

Søgeord:
Compac WD 60

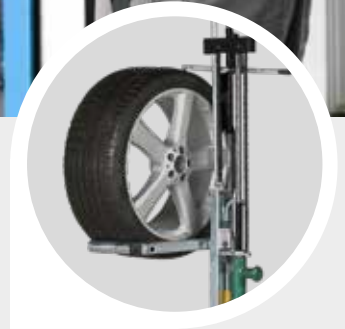

Kapacitet 60 kg. (Udvendig hjuldiameter max. 820 mm.)



Ruller med kuglelejer for let rotation og positionering.

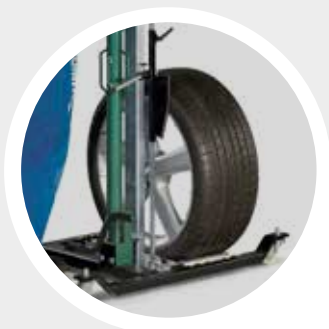

Ingen tunge løft. Hjulløfteren løfter hjulet direkte fra gulvhøjde.



WD 60



Fodbetjent løftefunktion.

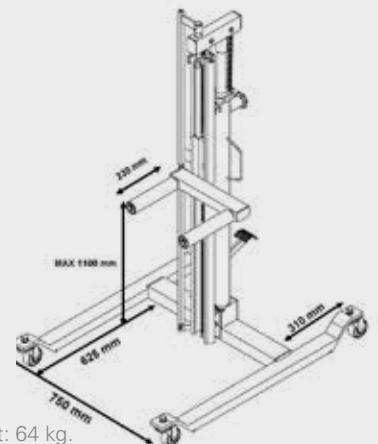

Vægt: 64 kg.



HJULLØFTER LASTBILER OG BUSSE



LET OG SIKKER MONTERING, DEMONTERING OG HÅNDTERING AF STORE HJUL PÅ LASTBILER OG BUSSE. IDEEL TIL SERVICEBILER

Ekstra hjul for let og sikker manøvrering selv under fuld belastning.

Ruller med kuglelejer for let rotation og positionering af hjulet.

Kapacitet
250 kg.

Vægt: 15 kg.

WD Mobile



Det ergonomiske håndtag gør hjulløfteren let at håndtere.

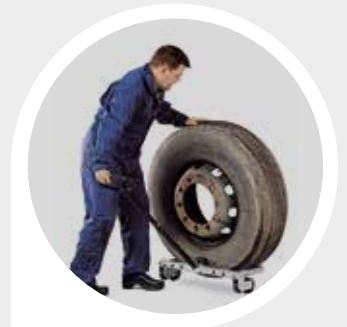

Kan håndtere meget store lastbilhjul. Eksempelvis 445/65 - 22,5.

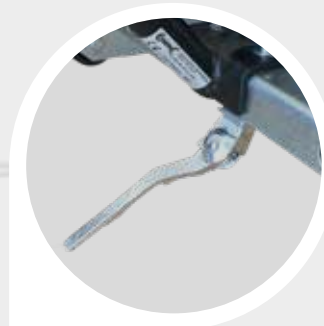

Støtteben til hurtig og let parkering uden last.



Rullerne kan justeres i bredden afhængigt af hjulstørrelsen. Tre positioner i hver side.

IDEEL TIL HÅNDTERING AF STORE, TUNGE HJUL PÅ BUSSE, LASTBILER OG VAREBILER

Maksimum løftehøjde 665 mm.

Dobbelt ruller med kuglelejer for separat rotation af hjulene ved montering og demontering.

WD 800

Kapacitet 800 kg.

Vægt: 136 kg.



Idéal til løft af tunge tvillinghjul.



Bærearmer kan indstilles i bredden for håndtering af hjul med en udvendig diameter fra Ø 545 mm - 1278 mm.

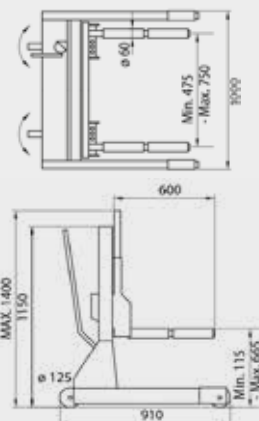

Hydraulikens placering giver brugeren et stort, åbent arbejdsområde.



EFFEKTIV OG SIKKER MONTERING, DEMONTERING OG HÅNDBERING AF STORE HJUL MED DIAMETER OP TIL 2400 MM





HJULLØFTER

LANDBRUGS- OG ENTREPRENØRMASKINER



Let håndtering af store hjul med diameter fra 1250 mm op til 2400 mm og bredde op til 1050 mm.



2 x 4 store ruller muliggør rotation af hjul med dybe dækmønstre.

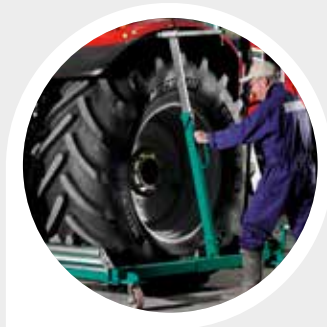

Hydraulikenhedens placering indvendigt i chassiset giver brugeren et stort åbent arbejdsområde.



"Hands-free" fodbetjent omskiftning mellem løfte- og sænkefunktion gør højdejustering let ved montering.

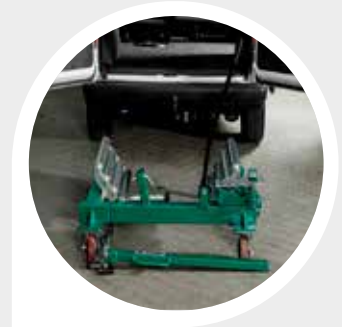

Mobil: Let at bruge uden for værkstedet. Kan skilles ad på få sekunder.

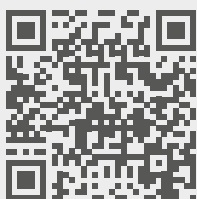

**You
Tube**

Søgeord:
Compac WD 1600

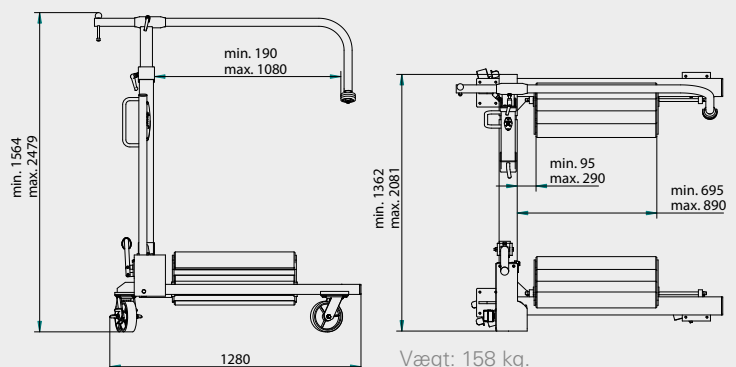



VÆRKSTEDSKRANER BILER



TILBEHØR



939010
Løfteåg.
Kapacitet 500 kg.

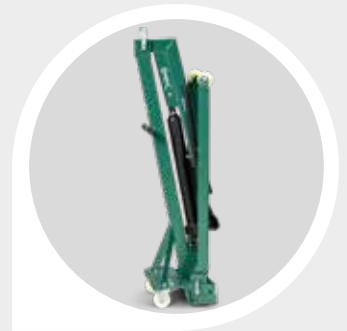

Sammenklappelig.
Pladsbesparende når kranen ikke er i brug. (35x42 cm)

CC 055 kapacitet:

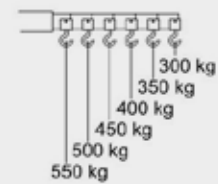

CC 10 kapacitet:

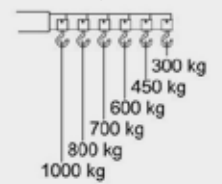

Den lave konstruktion af benene sikrer, at kranen let kan køres ind under meget lave biler.

88 mm.

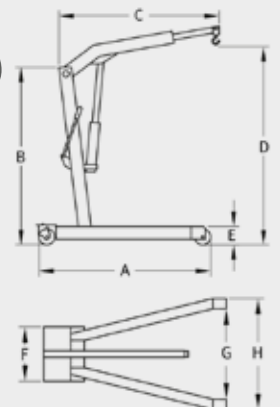

Model	A (mm)	B (mm)	C (mm)	D (mm)	E (mm)	F (mm)	G (mm)	H (mm)	Kg
CC 055	1530	1500	Min. 985 Max. 1435	2120 Max. 550 kg. 2455 Max. 300 kg.	88	440	865	1020	102
CC 10	1530	1500	Min. 985 Max. 1435	2120 Max. 1000 kg. 2455 Max. 300 kg.	88	440	865	1020	102



VÆRKSTEDSKRANER BILER OG INDUSTRIELT BRUG



Den ekstra lange rækkevidde, gør det let at løfte motorer ud af moderne biler.

Svingbar pumpeenhed gør, at kranen kan betjenes fra begge sider.



Værkstedskran med høj kapacitet til industrielt brug.



Benene på den industrielle værkstedskran passer rundt om en standard euro palle.

CC 15P kapacitet:

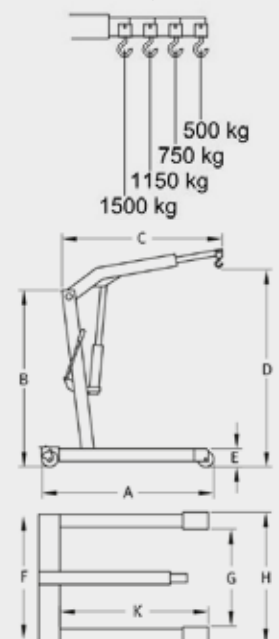

Model	A (mm)	B (mm)	C (mm)	D (mm)	E (mm)	F (mm)	G (mm)	H (mm)	K (mm)	Kg
CC 15P	1720	1860	Min. 1370 Max. 1820	2745 Max. 1500 kg. 3110 Max. 500 kg.	200	1000	850	1015	1570	168



UNIVERSALE GEARKASSELØFTERE BILER OG VAREBILER



Vendbar gearkasseadapter med saddele og gummibelægning.

Ideel til støtte og håndtering af udstødningssystemer, benzintanke, opgaver omkring hjulet, m.m.

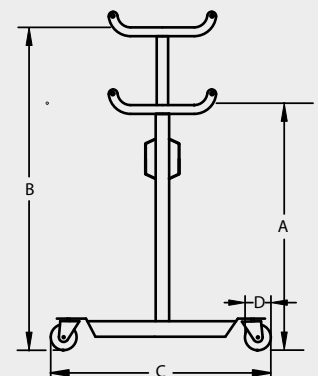
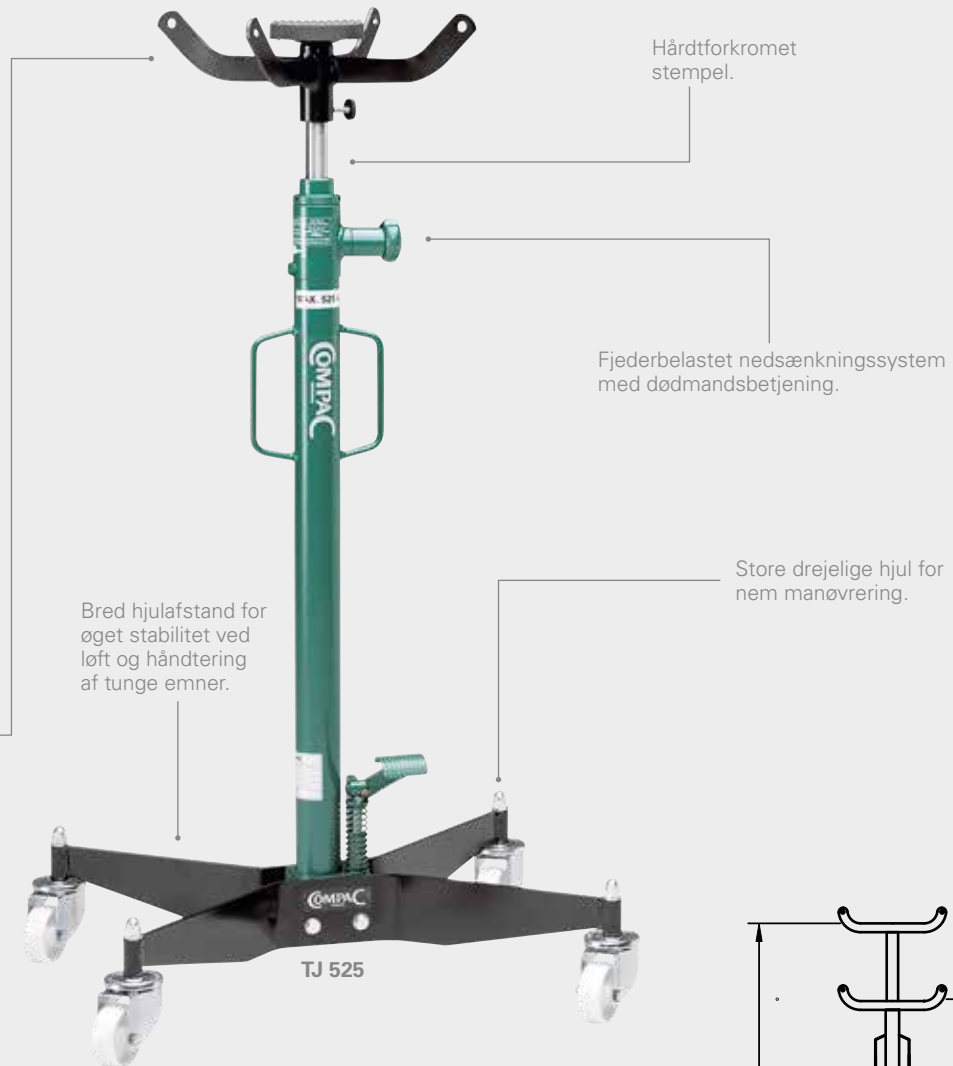

Model	Max (kg)	A (mm)	B (mm)	C (mm)	D (mm)	Kg
TJ 300	300	1095	1930	465 x 565	60	28
TJ 325	325	1170	2020	595 x 535	80	30
TJ 525	525	1170	2020	595 x 535	80	32
TJ 1000	1000	1170	2000	595 x 535	100	38



TILBEHØR TIL GEARKASSELØFTERE BILER OG VAREBILER



53012/53015



939014

TILBEHØR



Model	Nr.
TJ 300	53012
TJ 325	53012
TJ 525	53012
TJ 1000	53015
TJ-T 1300	53015

McPherson fjederbens støtte.
Bruges til at understøtte og dermed aflaste McPherson fjederben under demontering og montering af bl.a. bærekugler.

Disse arbejdsopgaver er normalt tidskrævende og besværlige, hvis man ikke har muligheden for hurtigt og let at understøtte fjederbenet.



Model	Nr.
TJ 300	53004
TJ 325	53004
TJ 525	53005
TJ 1000	53006
TJ-T 1300	53006

Væskeaftømningssæt inkl. adapter.
Ideel til hurtig og let aftømning af olie, kølevæske, m.m. 18,9 liter.



Model	Nr.
TJ 300	53010
TJ 325	53010
TJ 525	53011
TJ 1000	53013
TJ-T 1300	53013

Adapter.
Adapter uden arme. Forbedrer adgang til områder med begrænset plads.



Model	Nr.
TJ 300	-
TJ 325	-
TJ 525	939014
TJ 1000	939014
TJ-T 1300	939014

Gearkasseværktøj.
Kan justeres i to vinkler for optimal positionering ved håndtering af gearkasser. Kapacitet 300 kg.

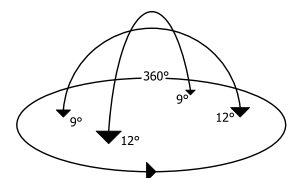



TELESKOPISK GEARKASSELØFTER BILER, VAREBILER OG 4WD



TILBEHØR

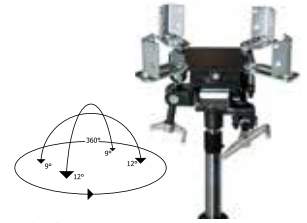

939014
Gearkasseværktøj.
Kan justeres i to vinkler for optimal positionering ved håndtering af gearkasser.

Kapacitet 300 kg.

939014



Hårdt forkromet stempel.

Ideel til demontering og montering af motor/gearkasse samlet.

To-trins cylinder for ekstra lav minimumshøjde og ekstra lang slaglængde.

Fjederbelastet nedsænkningssystem med dødmansbetjening.

To-trins pumpe for hurtig fremføring af stempel til emnet.

Bred hjulafstand for øget stabilitet ved løft og håndtering af tunge emner.

Min. højde 1000 mm.

Store drejelige hjul for nem manøvrering.

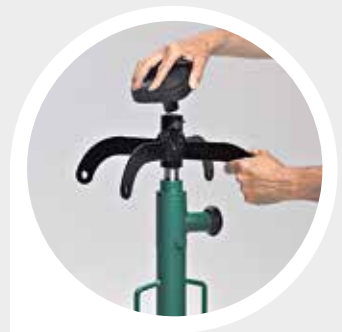

Vendbar gearkasseadapter med sadel og gummibelægning.

Ideel til støtte og håndtering af udstødningssystemer, benzintanke, opgaver omkring hjulet, m.m.



TJ-T 1300

TJ-T 1300

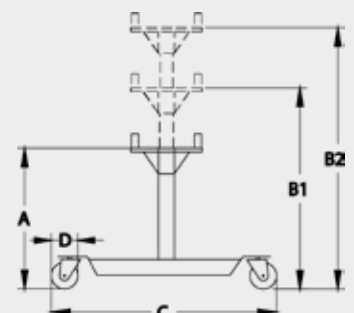

Model	Max (ton)	A (mm)	B1 (mm)	B2 (mm)	C (mm)	D (mm)	Kg
TJ-T 1300	1.3 / 0.5	1000	1500	2010	760 x 640	100	65



TELESKOPISK GEARKASSELØFTER LASTBILER OG BUSSE



TILBEHØR

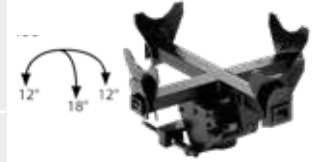

939007

Gearkasseværktøj kan justeres for optimal positionering og sikker håndtering af gearkasser.

Kapacitet 1000 kg.

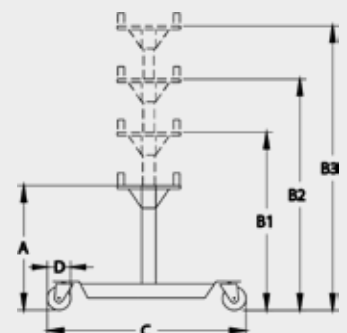
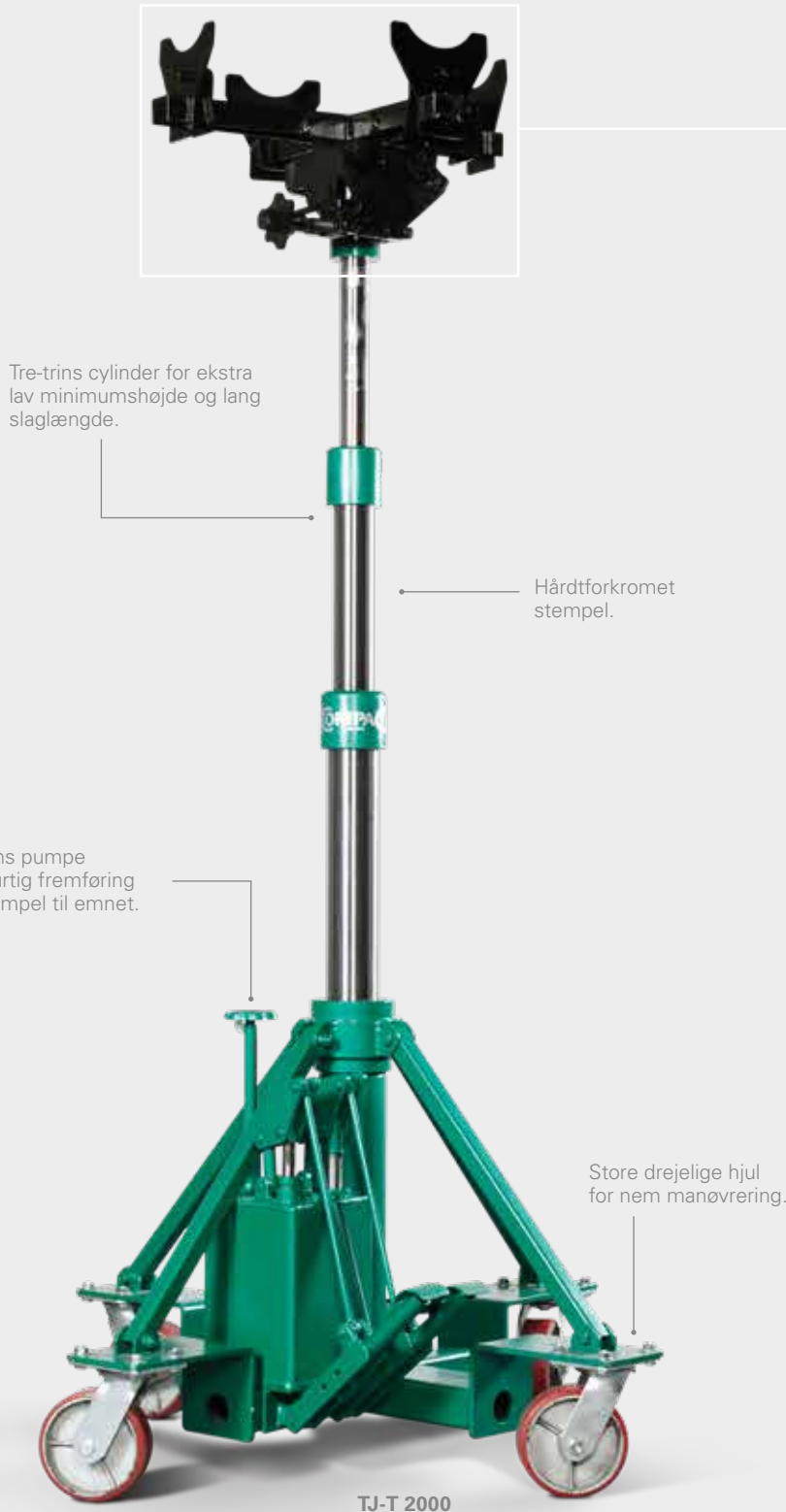

Model	Max (ton)	A (mm)	B1 (mm)	B2 (mm)	B2 (mm)	C (mm)	D (mm)	Kg
TJ-T 2000	2.0 / 1.0 / 1.0	960	1320	1600	1910	1050 x 1050	150	110



FJEDERSPÆNDEPRESSE BILER OG VAREBILER



EFFEKTIV OG SIKKER MONTERING OG DEMONTERING AF MCPHERSON FJEDERBENSYSYSTEMER

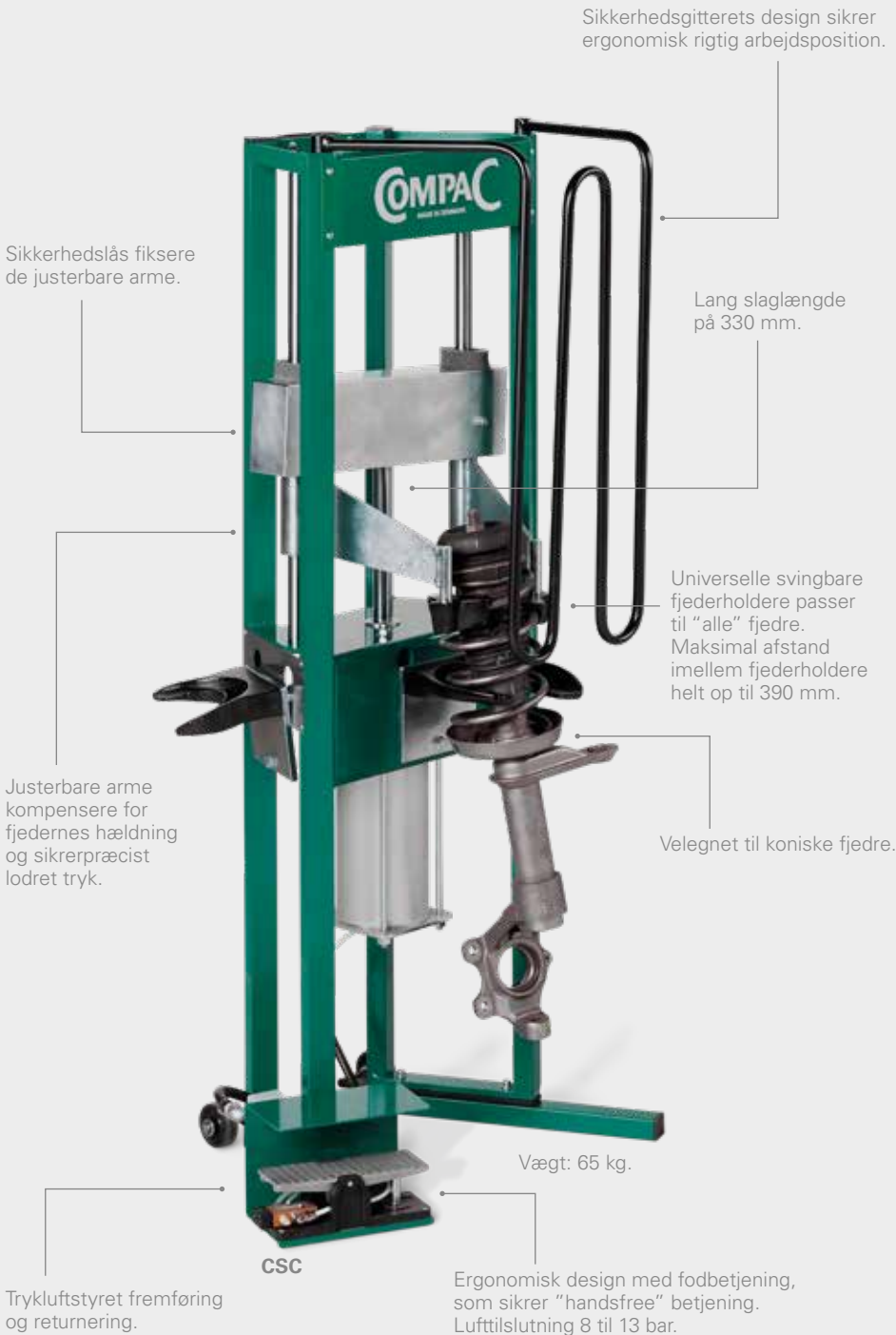

STANDARD



2 stk. universale fjederbakker
(Ø78 - 125 mm og Ø125 - 200 mm)

TILBEHØR



929050
Universal skruestik til McPherson fjederben.



McPherson fjederben monteret i struestikken. Tilbehør 929050.



Trykkraft nok til håndtering af kraftige fjedre på de fleste 4WD, SUV og varebiler f.eks. Ducato, Jumper og Boxer.



Mobil på værkstedet. Kan let flyttes mellem arbejdsstationer. Klar til brug på få sekunder.



FJEDERSPÆNDEPRESSE BILER OG VAREBILER



You
Tube

Søgeord:
Compac CSC

Nem adgang til montering og
demontering af top møtrik.



SPECIAL VÆRKTØJER



929052

Adapter til Mercedes A, B, C og E klasse. (C-klasse op til og med 2009)

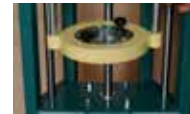

929059

Adapter til Mercedes C-klasse fra 2010 og nyere.



929051

Fjederbakke Ø105 - 182 mm.
Anbefales bla. til:
Renault Megane, Renault Clio, Citroën C2, Citroën C3, Peugeot 207, Peugeot 208, Peugeot 307, Fiat Multipla.
(Lereves med i Mercedes kit 929052)



929056

Adapter til Porsche Cayenne, VW Touareg.



929053

Fjederholdere med lave læber.



929060

Adapter til Renault Koleos, Renault Laguna, Nissan Qashqai.



929057

Skruestik til Chrysler Voyager og Mercedes.



FODBETJENTE VÆRKSTEDSPRESSER 16 - 25 TON BILER OG VAREBILER



TILBEHØR



61248
Lejeopsætningsværktøj.



Flytbar cylinder.

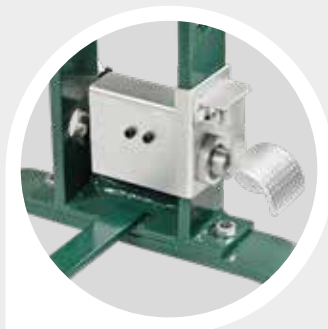

Hurtig, fodbetjent trykluftstyret fremføring af stempel. (FP 20/FP 25)

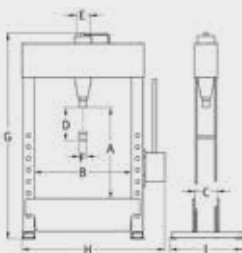

Hårdtforchromet stempel.

Lang slaglængde på 240 mm. (FP 20/FP 25)

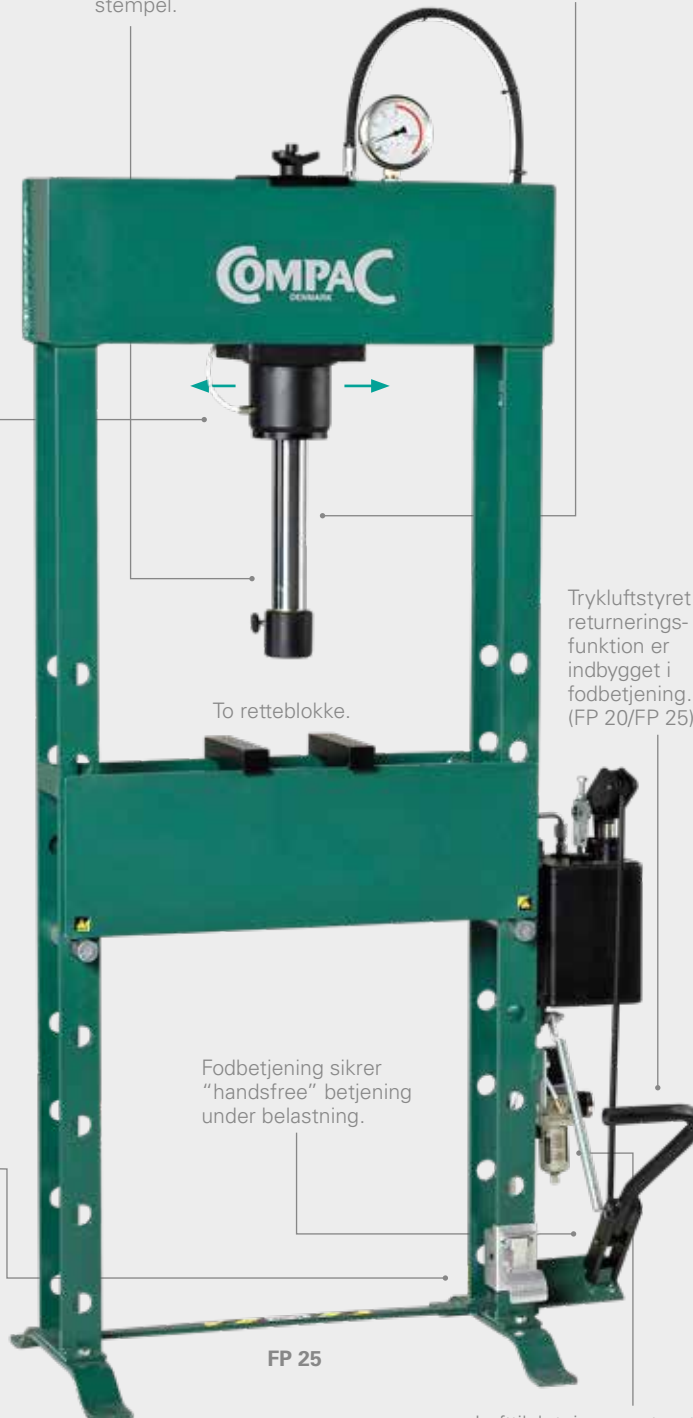

To retteblokke.

Fodbetjente sikrer "handsfree" betjening under belastning.

Trykluftstyret returneringsfunktion er indbygget i fodbetjening. (FP 20/FP 25)

Lufttilslutning monteret med vandudskiller. (FP 20/FP 25)

FP 25

TILBEHØR



61100
Presseplade.



61240
Hyldesystem til opbevaring af tilbehør.



Model	Nr.
FP 16	61219
FP 20	61216
FP 25	61216

Dornsæt.
7 stk. Ø12, 16, 18, 20, 22, 25, 30.



Model	Nr.
FP 16	61220
FP 20	61218
FP 25	61218

Lejeudpresningsæt.
4 stk. Ø64, 67, 72, 75.



61242
Beskyttelsesskærm.

Model	Max (ton)	(mm/stroke)	A (mm)	B (mm)	C (mm)	D (mm)	E (mm)	F (mm)	G (mm)	H (mm)	I (mm)	Kg
FP 16	16	6,0/2,0	1200	550	140	150	65	40	1780	850	600	125
FP 20	20	9,0/1,1	825	600	140	240	90	70	1800	890	505	154
FP 25	25	9,0/1,1	825	600	140	240	90	70	1800	890	505	154



HÅNDBETJENTE VÆRKSTEDSPRESSER 20 - 25 TON BILER OG VAREBILER



TILBEHØR



61248
Lejeopsætningsværktøj.



Flytbar cylinder.

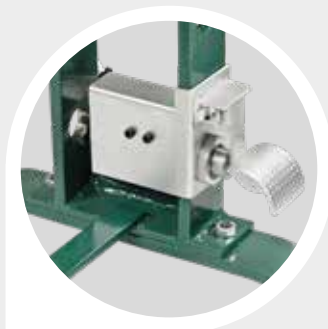

Hurtig, fodbetjent trykluftstyret fremføring af stempel.

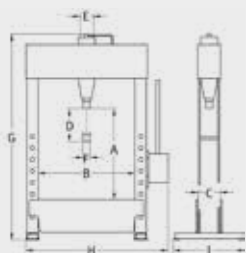

Hårdforkromet stempel.

Lang slaglængde på 240 mm.

Luftstyret returneringsfunktion er indbygget i pumpehåndtaget.



COMPAC
DENMARK

To retteblokke.

HP 25

Lufttilslutning monteret med vandudskillere.

TILBEHØR



61100.
Presseplade.



61240
Hyldesystem til opbevaring af tilbehør.



Model	Nr.
HP 20	61216
HP 25	61216

Dornsæt.
7 stk. Ø12, 16, 18, 20, 22, 25, 30.



Model	Nr.
HP 20	61218
HP 25	61218

Lejeudpresningsæt.
4 stk. Ø64, 67, 72, 75.



61242
Beskyttelsesskærm.

Model	Max (ton)	(mm/stroke)	A (mm)	B (mm)	C (mm)	D (mm)	E (mm)	F (mm)	G (mm)	H (mm)	I (mm)	Kg
HP 20	20	9,0/4,0	825	600	140	240	90	70	1800	890	505	154
HP 25	25	9,0/4,0	825	600	140	240	90	70	1800	890	505	154



FODBETJENTE VÆRKSTEDSPRESSER 40 - 50 TON LASTBILER OG BUSSE



TILBEHØR



61248
Lejeopsætningsværktøj.

Model	Nr.
FP 40	61248
FP 50	61248



Spil med automatisk bremse til hurtig og let justering af bordhøjde.



Hurtig, fodbetjent trykluftstyret fremføring af stempel.

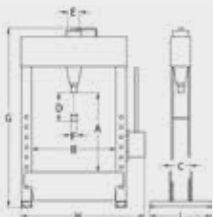

TILBEHØR



61100
Presseplade.



61240
Hylde system til opbevaring af tilbehør.



Model	Nr.
FP 40	61216
FP 50	61216

Dornsæt.
7 stk. Ø12, 16, 18, 20, 22, 25, 30.



Model	Nr.
FP 40	61218
FP 50	61218

Lejudpresningssæt.
4 stk. Ø64, 67, 72, 75.



Model	Nr.
FP 40	61243
FP 50	61243

Beskyttelsesskærm.

Model	Max (ton)	(mm/stroke)	A (mm)	B (mm)	C (mm)	D (mm)	E (mm)	F (mm)	G (mm)	H (mm)	I (mm)	Kg
FP 40	40	6,0/1,0	750	840	200	300	125	70	1990	1350	630	370
FP 50	50	6,0/1,0	750	840	200	300	125	70	1990	1350	630	370



HÅNDBETJENTE VÆRKSTEDSPRESSER 40 - 100 TON LASTBILER OG BUSSE



TILBEHØR



61248
Lejeopsætningsværktøj.

Model	Nr.
HP 40	61248
HP 50	61248
HP 60	-
HP 70	-
HP 100	-



Spil med automatisk bremse til hurtig og let justering af bordhøjde.



Hurtig, fodbetjent trykluftstyret fremføring af stempel.



TILBEHØR



61100
Presseplade.



61240
Hyldesystem til opbevaring af tilbehør.



Model	Nr.
HP 40	61216
HP 50	61216
HP 60	61228
HP 70	61228
HP 100	61233

Dornsæt.
7 stk. Ø12, 16, 18, 20, 22, 25, 30.



Model	Nr.
HP 40	61218
HP 50	61218
HP 60	61229
HP 70	61229
HP 100	61234

Lejeudpresningssæt.
4 stk. Ø64, 67, 72, 75.



Model	Nr.
HP 40	61243
HP 50	61243
HP 60	61245
HP 70	61245
HP 100	61247

Beskyttelseskærm.

Model	Max (ton)	(mm/stroke)	A (mm)	B (mm)	C (mm)	D (mm)	E (mm)	F (mm)	G (mm)	H (mm)	I (mm)	Kg
HP 40	40	6,0/2,0	750	840	200	300	125	70	1990	1350	630	370
HP 50	50	6,0/2,0	750	840	200	300	125	70	1990	1350	630	370
HP 60	60	5,0/0,8	760	1005	255	300	160	80	2100	1615	710	680
HP 70	70	5,0/0,8	760	1005	255	300	160	80	2100	1615	710	680
HP 100	100	3,4/0,8	915	1035	305	300	200	100	2200	1637	800	946



ELEKTRO-HYDRAULISKE VÆRKSTEDSPRESSER 40 - 60 TON ENKELTVIRKENDE CYLINDER



TILBEHØR



61248
Lejeopsætningsværktøj.

Model	Nr.
EP 40	61248
EP 60	-

≡ **Enkeltvirkende cylinder:**
Cylinder uden trækraft. Anbefales kun ved presseopgaver hvor montering af værktøjer ikke kræves.



Spil med automatisk bremse til hurtig og let justering af bordhøjde.



Pumpeenheden kan svinges 90 grader væk fra pressen.

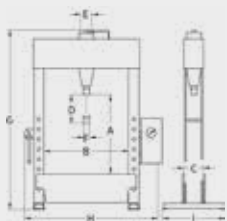

TILBEHØR



61100
Presseplade.



61240
Hyldesystem til opbevaring af tilbehør.



Model	Nr.
EP 40	61216
EP 60	61228

Domsæt.
7 stk. Ø12, 16, 18, 20, 22, 25, 30.



Model	Nr.
EP 40	61218
EP 60	61229

Lejeudpresningssæt.
4 stk. Ø64, 67, 72, 75.



Model	Nr.
EP 40	61243
EP 60	61245

Beskyttelsesskærm.

Model	Max (ton)	(mm/stroke)	A (mm)	B (mm)	C (mm)	D (mm)	E (mm)	F (mm)	G (mm)	H (mm)	I (mm)	Kg	Kw
EP 40	40	10,0	750	840	200	300	125	70	1990	1480	630	407	2,2
EP 60	60	10,0/5,0	760	1000	255	300	160	80	2100	1680	710	707	2,2



ELEKTRO-HYDRAULISKE VÆRKSTEDSPRESSER 40 - 100 TON DOBBELTVIRKENDE CYLINDER



TILBEHØR



61248
Lejeopsætningsværktøj.

Model	Nr.
EP 40 D	61248
EP 60 D	-
EP 100 D	-



Spil med automatisk bremse til hurtig og let justering af bordhøjde.



Pumpeenheden kan svinges 90 grader væk fra pressen.

Dobbeltvirkende cylinder:
Cylinder med både tryk- og trækraft.



EP 40 D

Model	Max (ton)	(mm/stroke)	Max (ton)	A (mm)	B (mm)	C (mm)	D (mm)	E (mm)	F (mm)	G (mm)	H (mm)	I (mm)	Kg	Kw
EP 40 D	40	10,0	6	750	840	200	300	125	70	1990	1480	630	407	2,2
EP 60 D	60	10,0/5,0	6	760	1000	255	300	160	80	2100	1680	710	707	2,2
EP 100 D	100	10,0/1,4	4	915	1035	305	300	200	100	2200	1780	800	996	2,2

TILBEHØR



61100
Presseplade.



61240
Hyldesystem til opbevaring af tilbehør.



Model	Nr.
EP 40 D	61216
EP 60 D	61228
EP 100 D	61233

Domsæt.
7 stk. Ø12, 16, 18, 20, 22, 25, 30.



Model	Nr.
EP 40 D	61218
EP 60 D	61229
EP 100 D	61234

Lejeudpresningssæt.
4 stk. Ø64, 67, 72, 75.



Model	Nr.
EP 40 D	61243
EP 60 D	61245
EP 100 D	61247

Beskyttelseskærm.



STØTTEBUKKE 2 - 12 TON FLASKEDONKRAFTE 3 - 50 TON BILER, LASTBILER OG LANDBRUG



SHARK&CO



STØTTEBUKKE

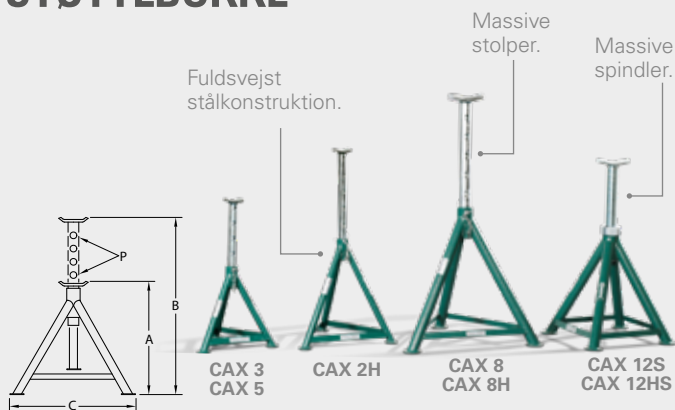

Model	Max (ton)	A (mm)	B (mm)	C (mm)	P	Kg
CAX 2H	2	420	650	410	5	5,6
CAX 3	3	320	560	330	5	4,6
CAX 5	5	380	600	360	5	6,9
CAX 8	8	400	600	400	5	10,9
CAX 8H	8	600	980	580	6	15,4
CAX 12S	12	340	500	290	Spindel	11,8
CAX 12HS	12	500	740	410	Spindel	15,6

FLASKEDONKRAFTE



Kan bruges i vandret position.
Begrænset slaglængde.



Model	Max (ton)	A (mm)	B (mm)	C (mm)	D (mm)	E (mm)	F (mm)	Kg
CBJ 3	3	193	120	60	373	110x103	26	3,4
CBJ 5	5	210	136	70	416	122x115	30	4,5
CBJ 10	10	230	150	80	460	132x120	36	5,9
CBJ 15	15	230	150	60	440	144x134	43	7,3
CBJ 20	20	242	150	60	452	159x143	46	9,5
CBJ 30	30	275	165	-	440	169x153	49	12,4
CBJ 50	50	265	160	-	425	210x176	83	25,7
CBJ-T 10	10	215	247	78	540	150x145	37	9,8

Compac forbeholder sig ret til at lade produkter udgå, ændre priser og levere produkter der er forskellige fra illustrationer og specifikationer.

Compac Hydraulik A/S

Strandhusevej 43 // 7130 Juelsminde // Danmark // Tel: +45 75 69 37 22 // info@compac.dk
www.compac.dk